

Introduction to CMOS VLSI Design

Lecture 11: Adders

David Harris

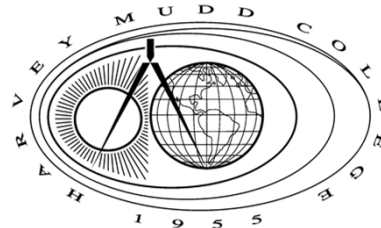

Harvey Mudd College

Spring 2004

Outline

- Single-bit Addition
- Carry-Ripple Adder
- Carry-Skip Adder
- Carry-Lookahead Adder
- Carry-Select Adder
- Carry-Increment Adder
- Tree Adder

Single-Bit Addition

Half Adder

$S =$

$C_{out} =$

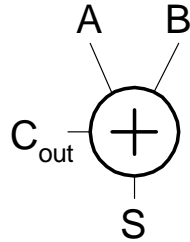

A	B	C_{out}	S
0	0		
0	1		
1	0		
1	1		

Full Adder

$S =$

$C_{out} =$

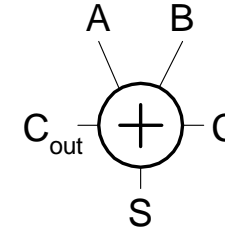

A	B	C	C_{out}	S
0	0	0		
0	0	1		
0	1	0		
0	1	1		
1	0	0		
1	0	1		
1	1	0		
1	1	1		

Single-Bit Addition

Half Adder

$$S = A \oplus B$$

$$C_{out} = A \cdot B$$

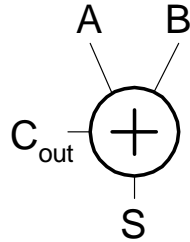

A	B	C_{out}	S
0	0	0	0
0	1	0	1
1	0	0	1
1	1	1	0

Full Adder

$$S = A \oplus B \oplus C$$

$$C_{out} = MAJ(A, B, C)$$

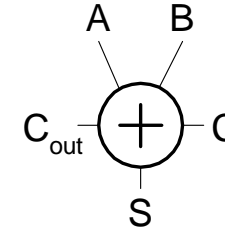

A	B	C	C_{out}	S
0	0	0	0	0
0	0	1	0	1
0	1	0	0	1
0	1	1	1	0
1	0	0	0	1
1	0	1	1	0
1	1	0	1	0
1	1	1	1	1

PGK

- For a full adder, define what happens to carries
 - Generate: $C_{out} = 1$ independent of C
 - G =
 - Propagate: $C_{out} = C$
 - P =
 - Kill: $C_{out} = 0$ independent of C
 - K =

PGK

- For a full adder, define what happens to carries
 - Generate: $C_{out} = 1$ independent of C
 - $G = A \cdot B$
 - Propagate: $C_{out} = C$
 - $P = A \oplus B$
 - Kill: $C_{out} = 0$ independent of C
 - $K = \sim A \cdot \sim B$

Full Adder Design I

- Brute force implementation from eqns

$$S = A \oplus B \oplus C$$

$$C_{\text{out}} = \text{MAJ}(A, B, C)$$

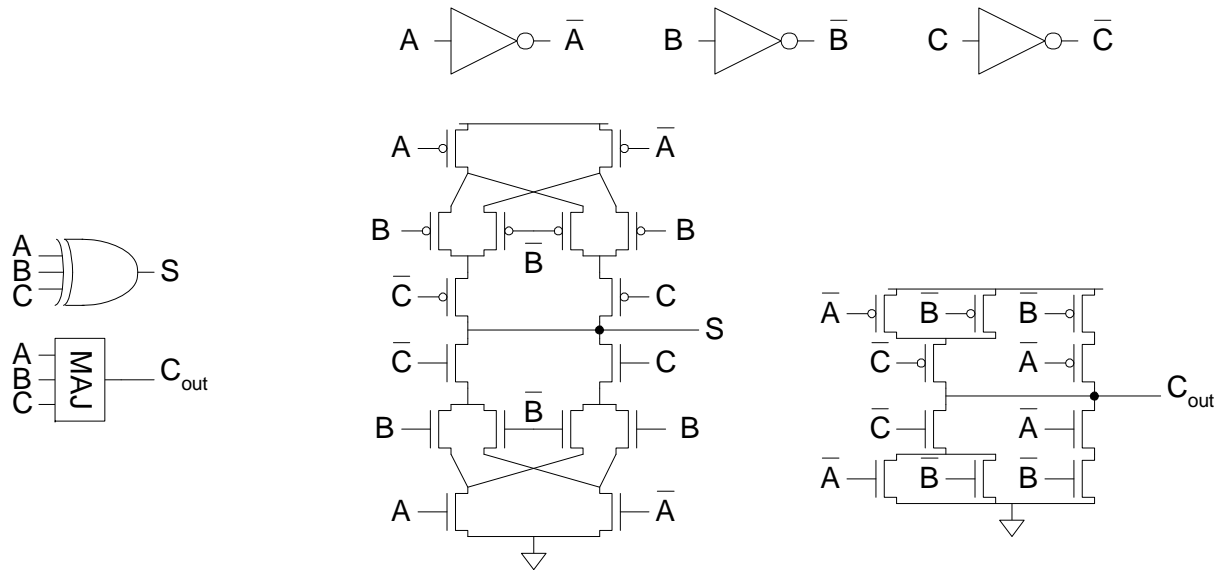

Full Adder Design II

- ❑ Factor S in terms of C_{out}
$$S = ABC + (A + B + C)(\sim C_{out})$$
- ❑ Critical path is usually C to C_{out} in ripple adder

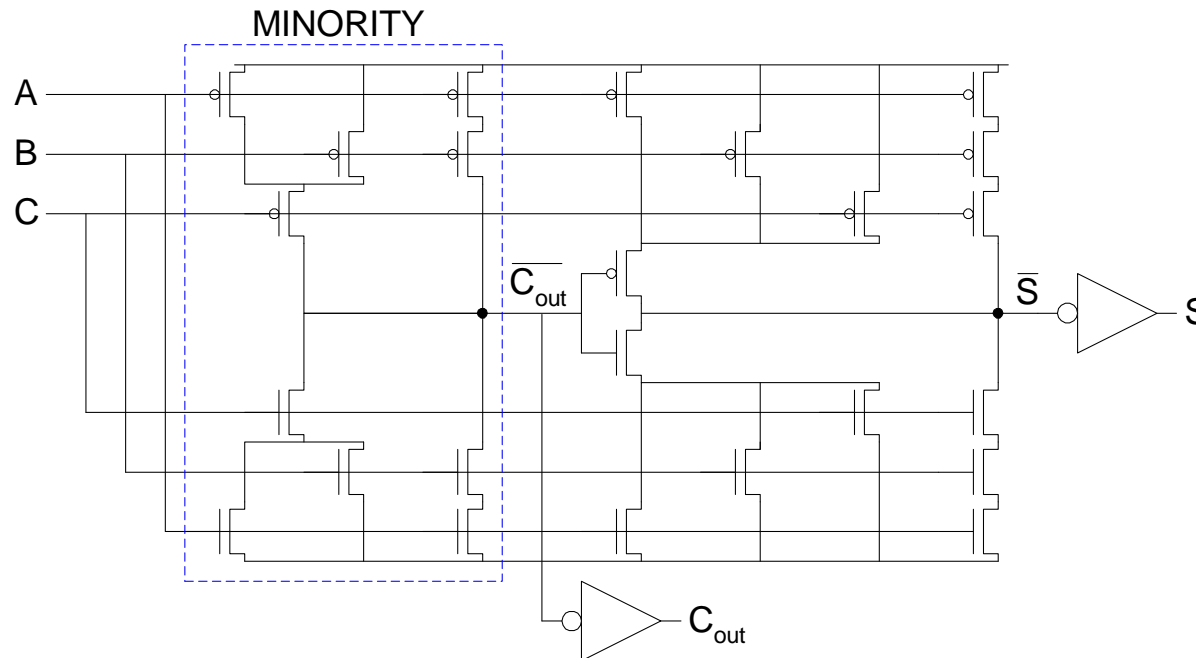

Layout

- ❑ Clever layout circumvents usual line of diffusion
 - Use wide transistors on critical path
 - Eliminate output inverters

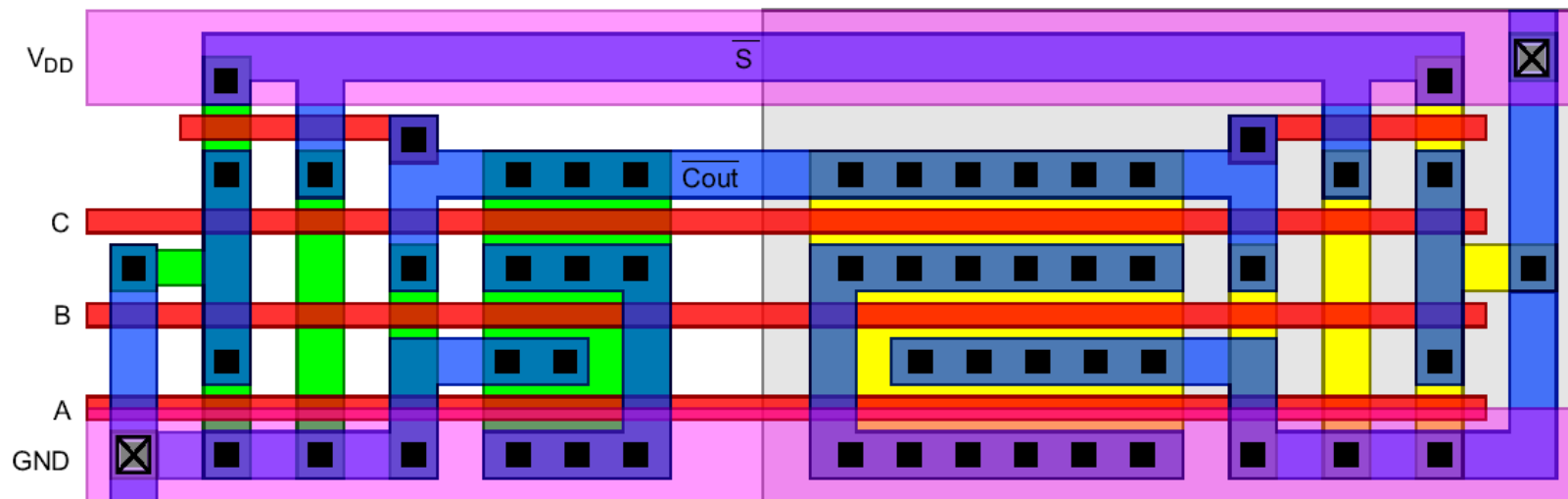

Full Adder Design III

- ❑ Complementary Pass Transistor Logic (CPL)
 - Slightly faster, but more area

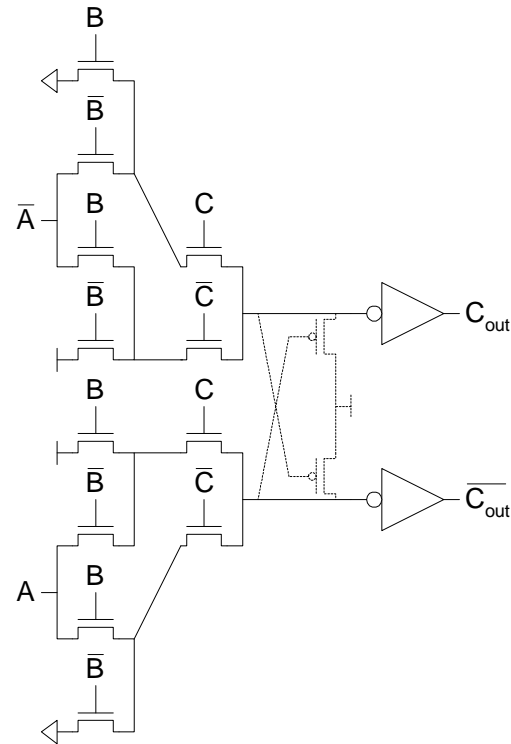
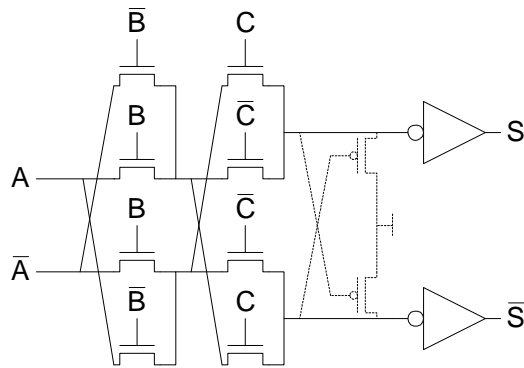

Full Adder Design IV

□ Dual-rail domino

- Very fast, but large and power hungry
- Used in very fast multipliers

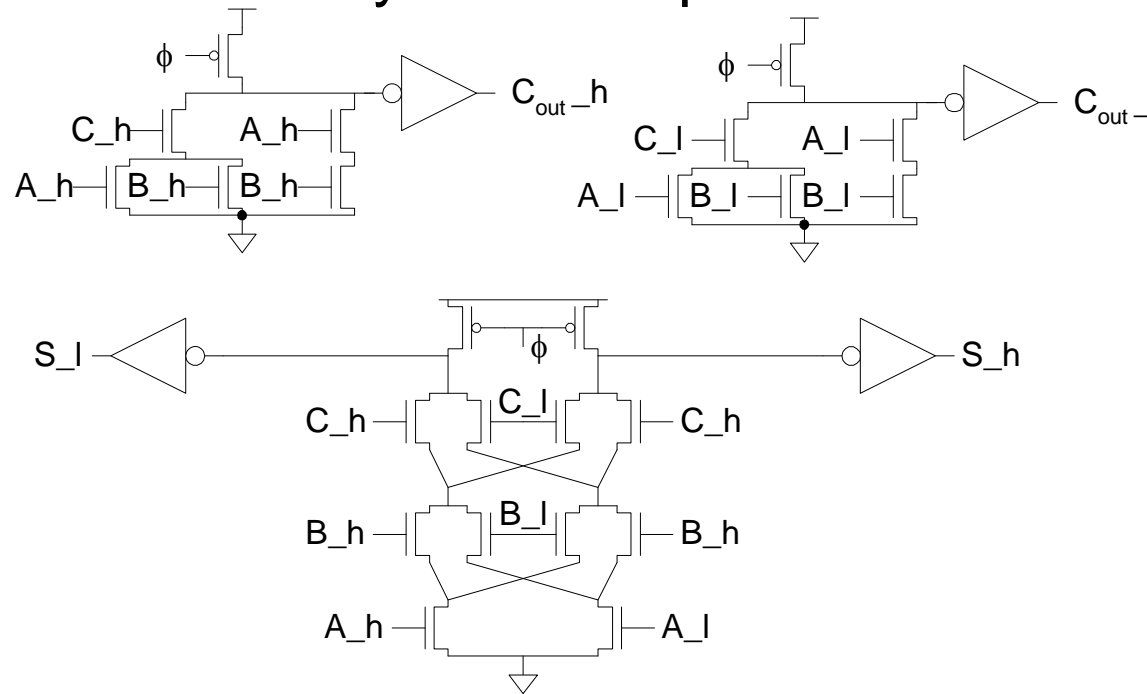

Carry Propagate Adders

- N-bit adder called CPA
 - Each sum bit depends on all previous carries
 - How do we compute all these carries quickly?

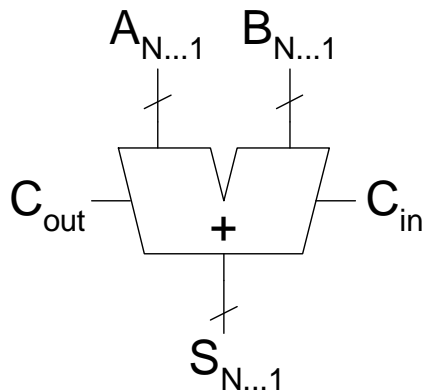

$$\begin{array}{r} \text{C}_{out} \swarrow \quad \nwarrow \text{C}_{in} \\ \textcircled{0}0000\textcircled{0} \\ 1111 \\ +0000 \\ \hline 1111 \end{array}$$

$$\begin{array}{r} \text{C}_{out} \swarrow \quad \nwarrow \text{C}_{in} \\ \textcircled{1}1111\textcircled{1} \quad \text{carries} \\ 1111 \quad A_{4...1} \\ +0000 \quad B_{4...1} \\ \hline 0000 \quad S_{4...1} \end{array}$$

Carry-Ripple Adder

- Simplest design: cascade full adders
 - Critical path goes from C_{in} to C_{out}
 - Design full adder to have fast carry delay

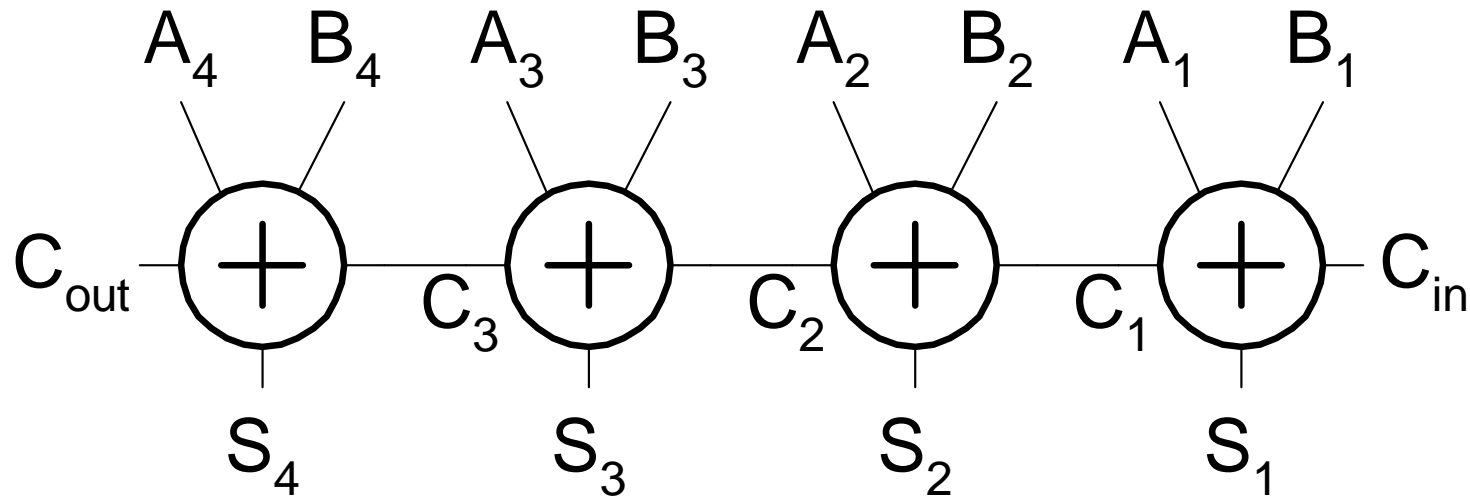

Inversions

- ❑ Critical path passes through majority gate
 - Built from minority + inverter
 - Eliminate inverter and use inverting full adder

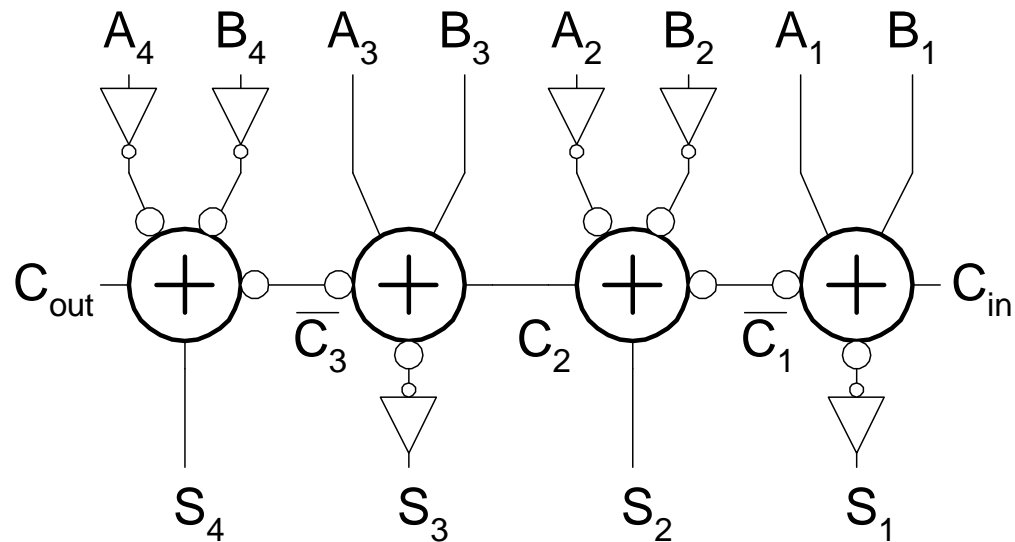

Generate / Propagate

- Equations often factored into G and P
- Generate and propagate for groups spanning i:j

$$G_{i:j} =$$

$$P_{i:j} =$$

- Base case

$$G_{i:i} \equiv G_i =$$

$$P_{i:i} \equiv P_i =$$

$$G_{0:0} \equiv G_0 =$$

$$P_{0:0} \equiv P_0 =$$

- Sum:

$$S_i =$$

Generate / Propagate

- Equations often factored into G and P
- Generate and propagate for groups spanning i:j

$$G_{i:j} = G_{i:k} + P_{i:k} \square G_{k-1:j}$$

$$P_{i:j} = P_{i:k} \square P_{k-1:j} \quad \dots\dots\dots$$

- Base case

$$G_{i:i} \equiv G_i = A_i \square B_i$$

$$P_{i:i} \equiv P_i = A_i \oplus B_i$$

$$G_{0:0} \equiv G_0 = C_{in}$$

$$P_{0:0} \equiv P_0 = 0$$

- Sum:

$$S_i = P_i \oplus G_{i-1:0}$$

PG Logic

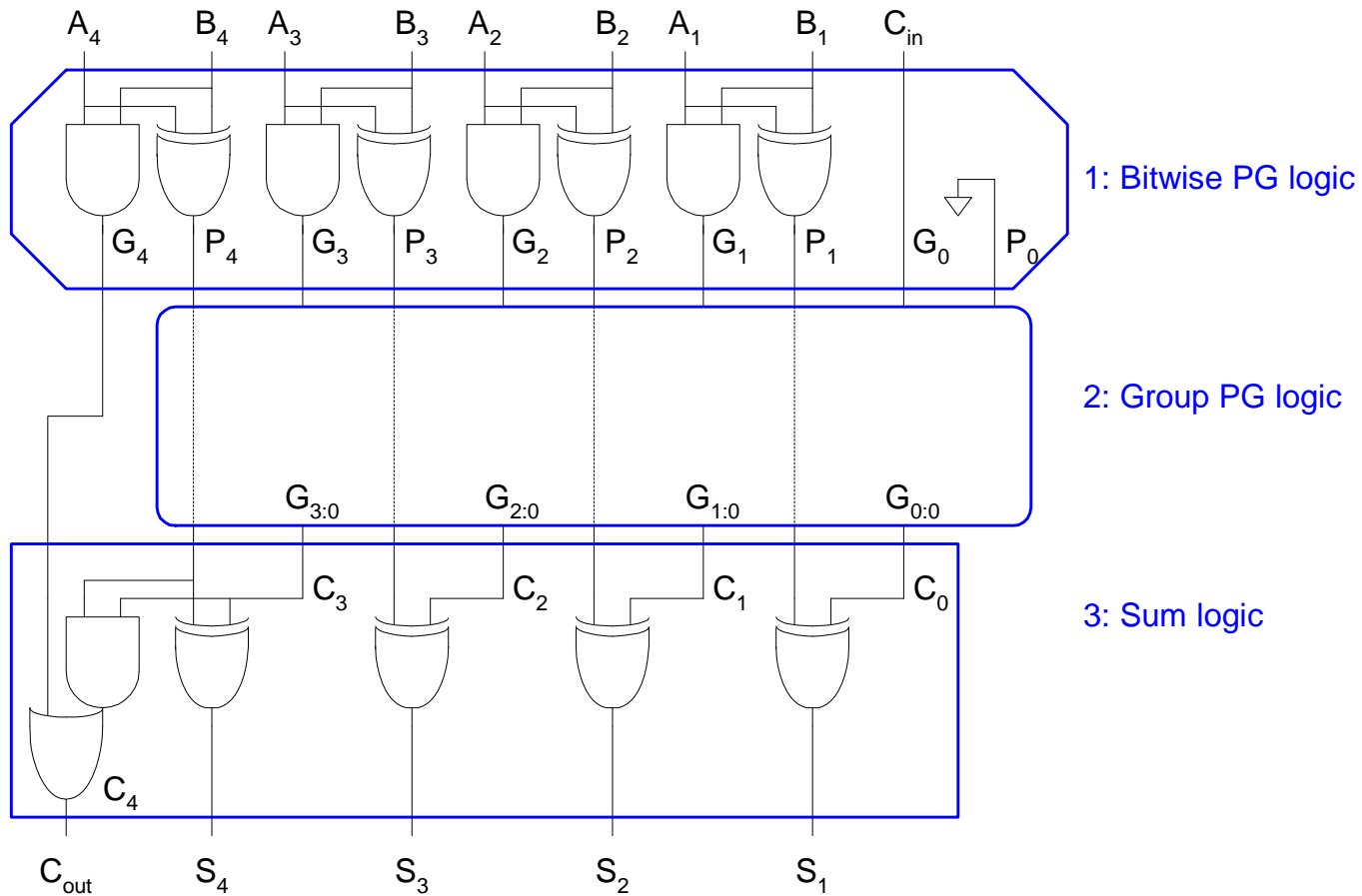

Carry-Ripple Revisited

$$G_{i:0} = G_i + P_i \square G_{i-1:0}$$

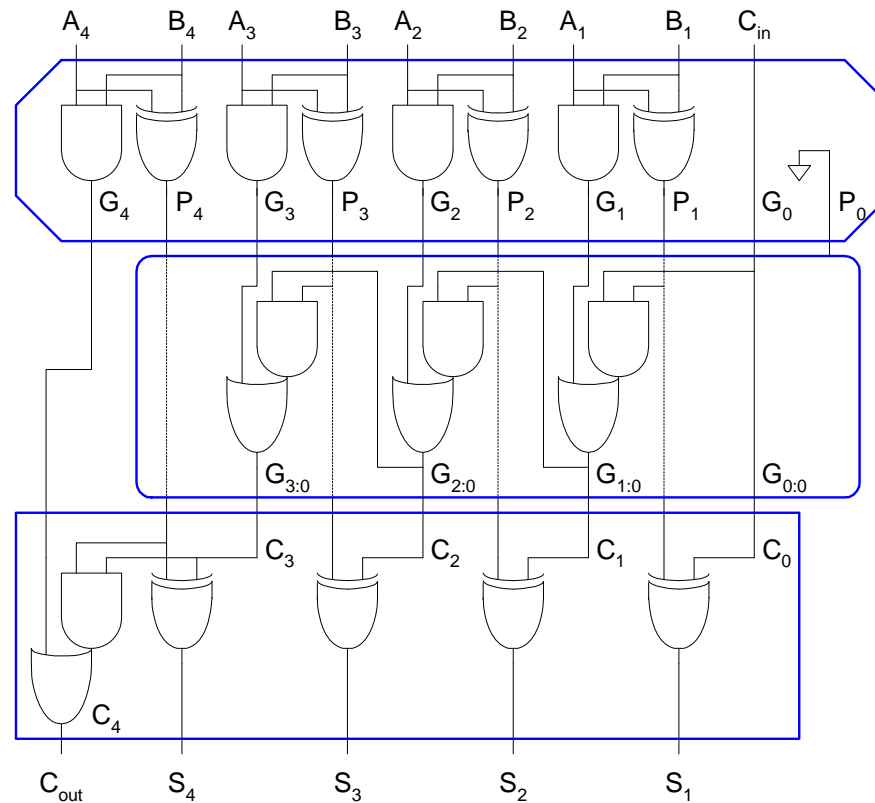

Carry-Ripple PG Diagram

$t_{\text{ripple}} =$

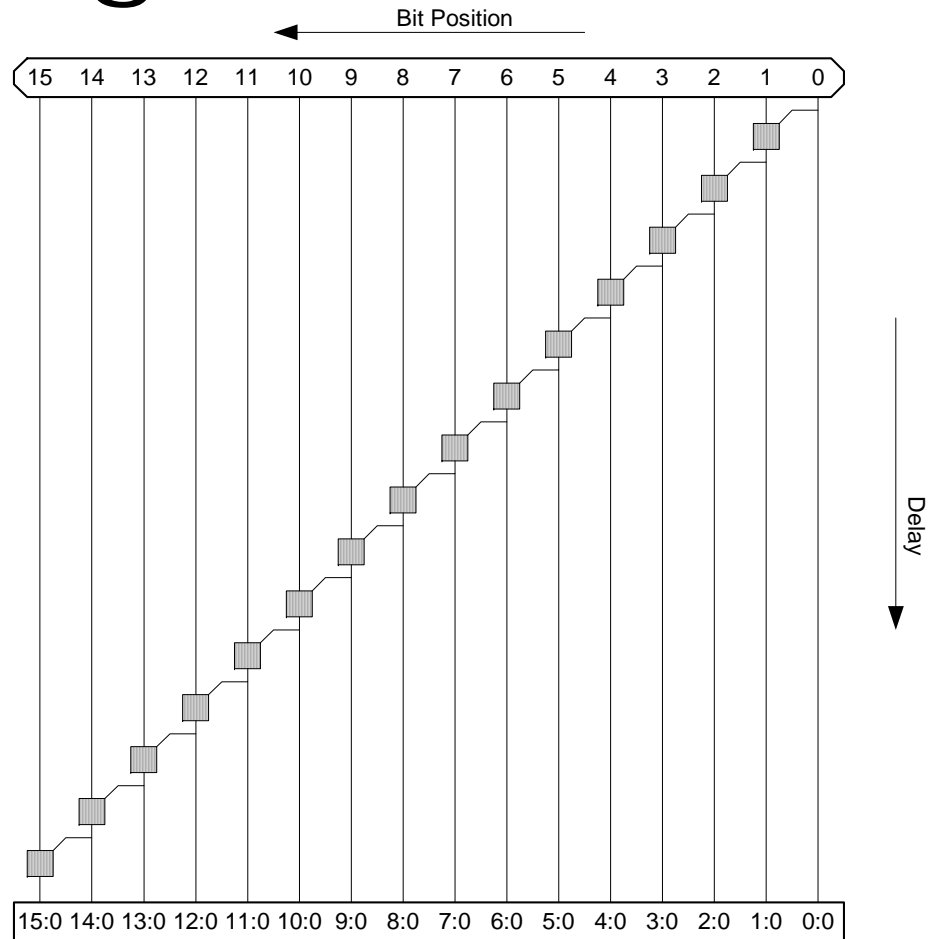

Carry-Ripple PG Diagram

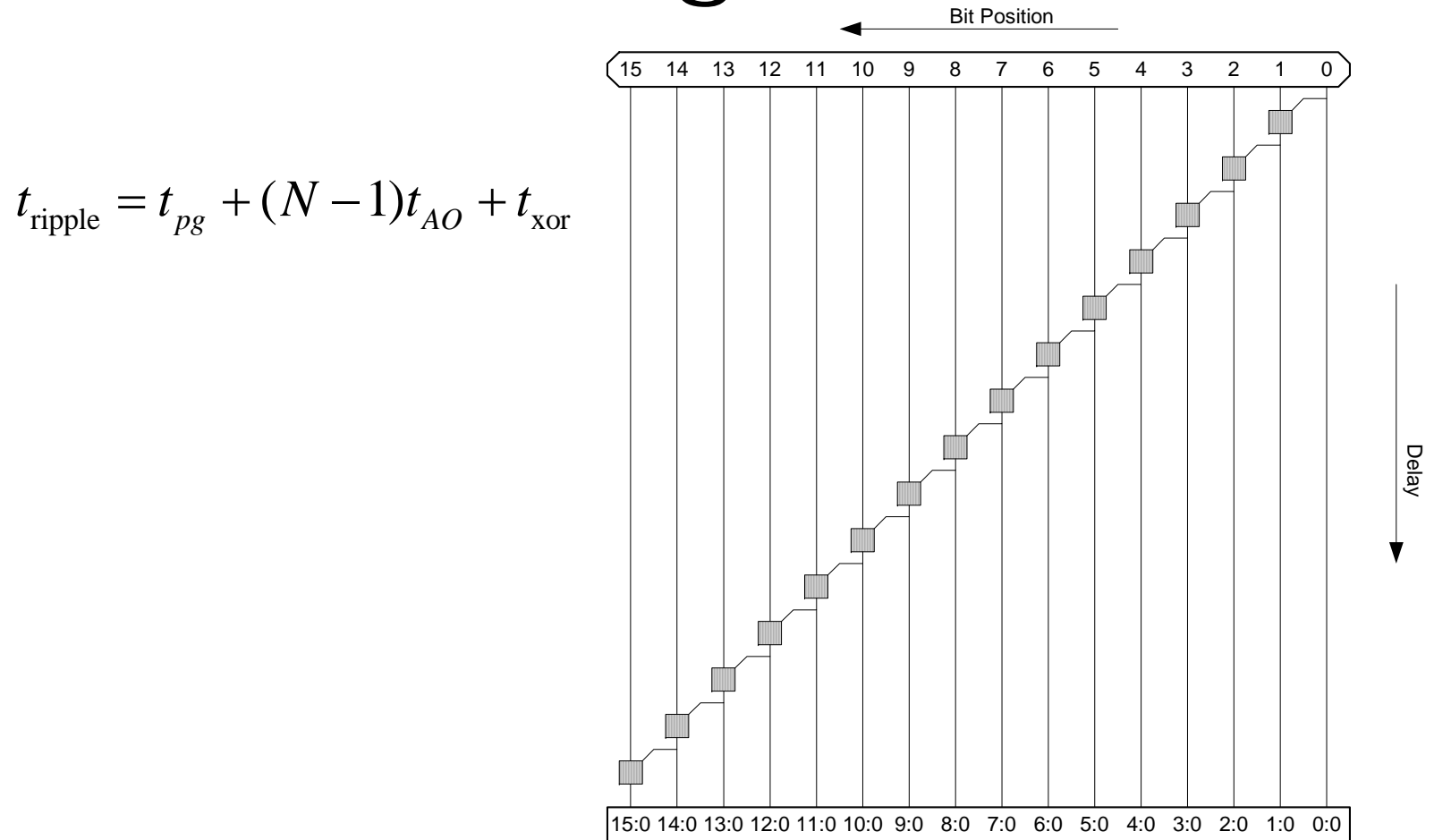

PG Diagram Notation

Black cell

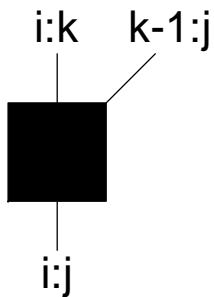

Gray cell

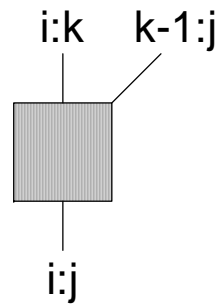

Buffer

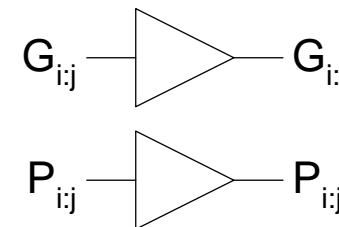
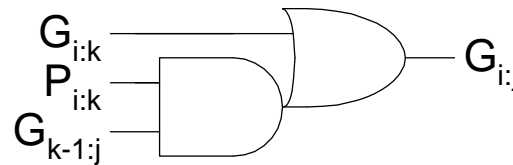
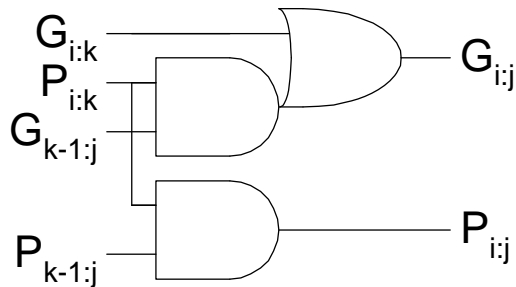
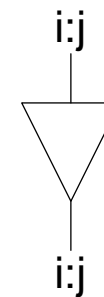

Carry-Skip Adder

- ❑ Carry-ripple is slow through all N stages
- ❑ Carry-skip allows carry to skip over groups of n bits
 - Decision based on n-bit propagate signal

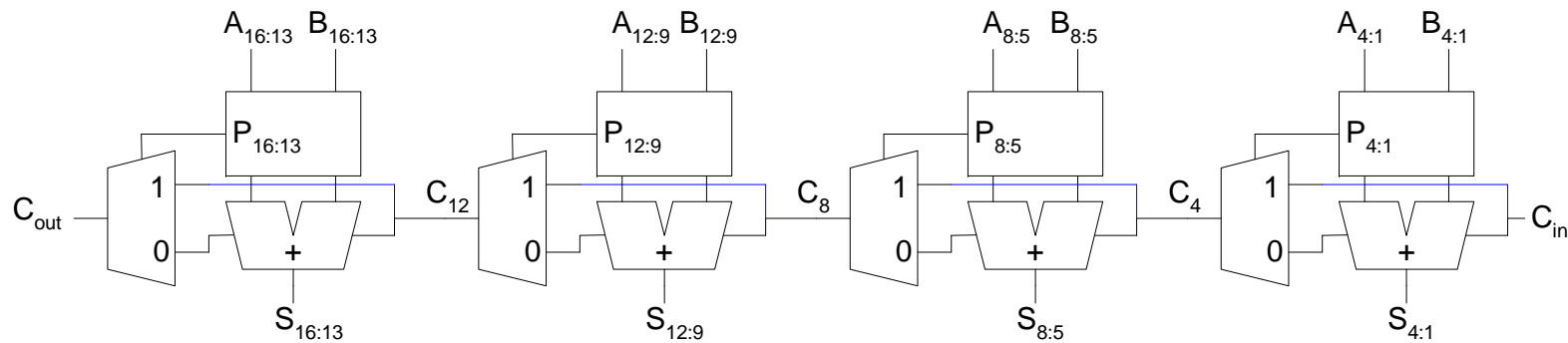

Carry-Skip PG Diagram

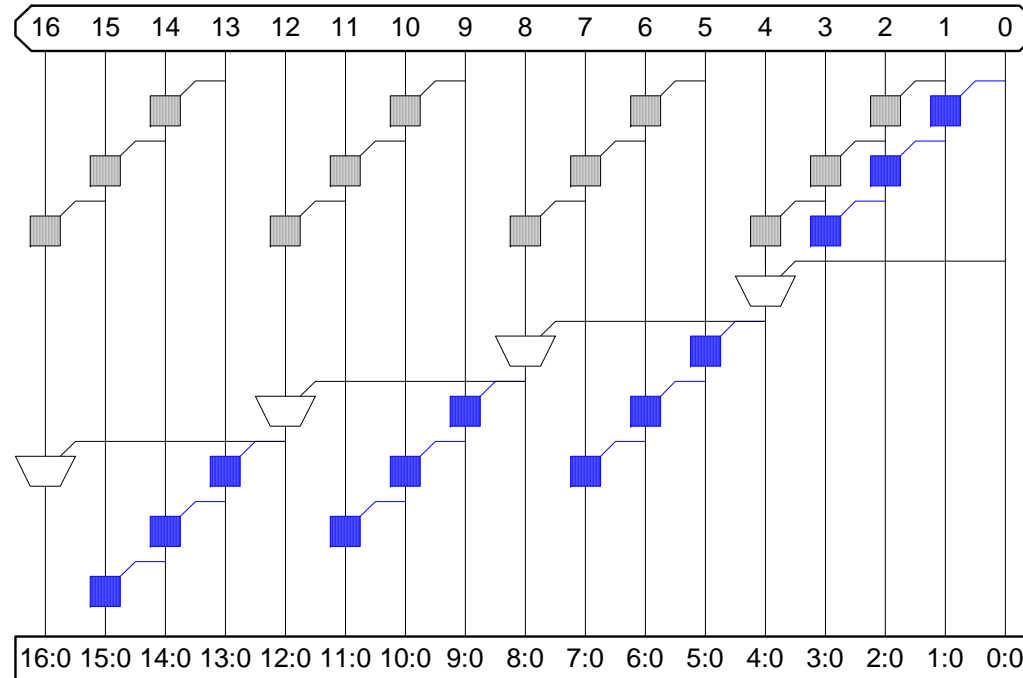

For k n-bit groups ($N = nk$)

$$t_{\text{skip}} =$$

Carry-Skip PG Diagram

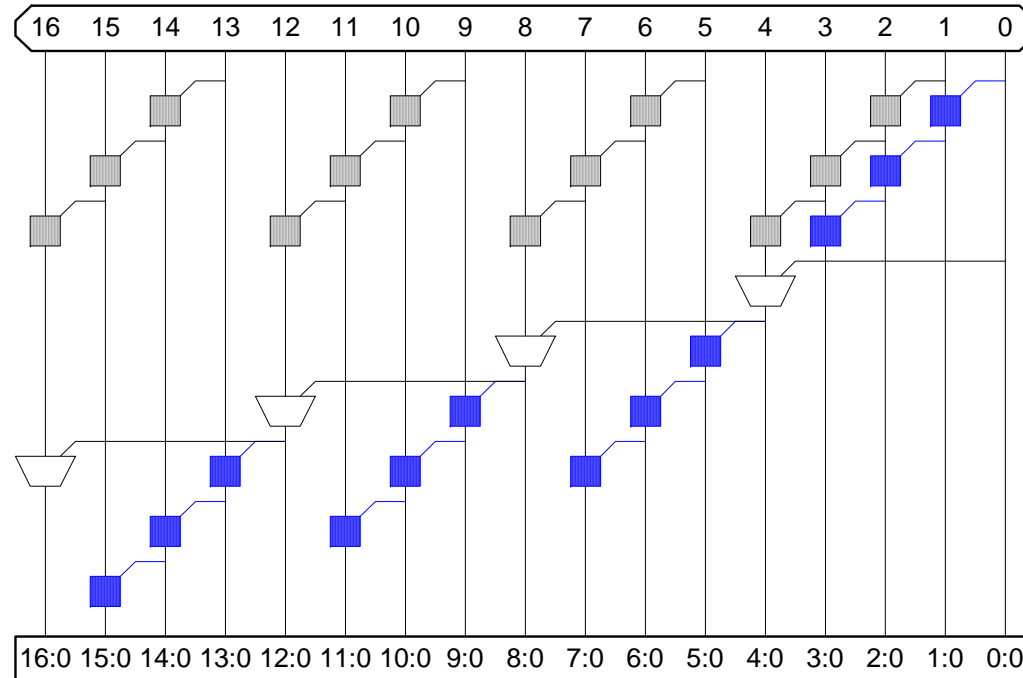

For k n-bit groups ($N = nk$)

$$t_{\text{skip}} = t_{pg} + [2(n-1) + (k-1)]t_{AO} + t_{\text{xor}}$$

Variable Group Size

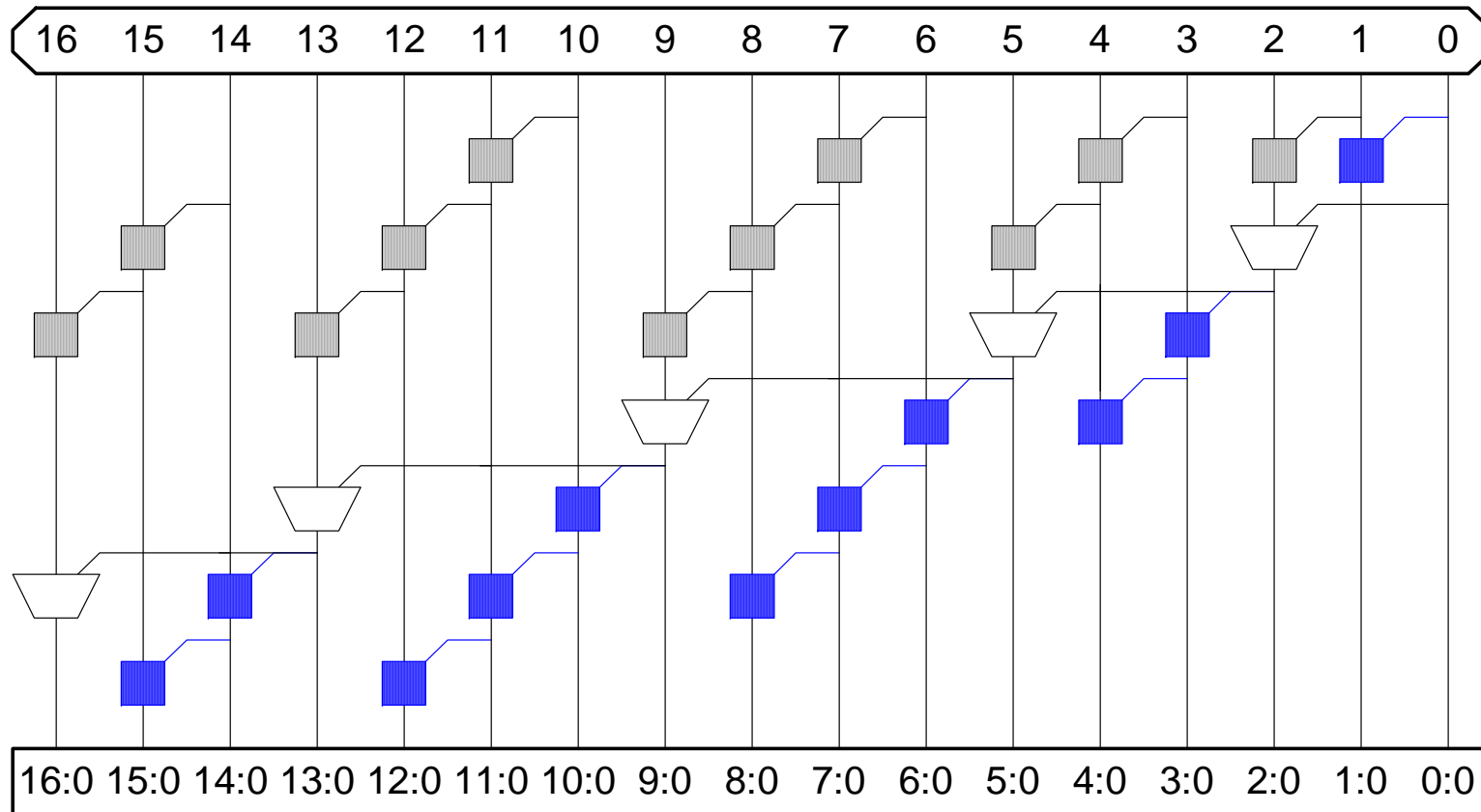

Delay grows as $O(\sqrt{N})$

Carry-Lookahead Adder

- ❑ Carry-lookahead adder computes $G_{i:0}$ for many bits in parallel.
- ❑ Uses higher-valency cells with more than two inputs.

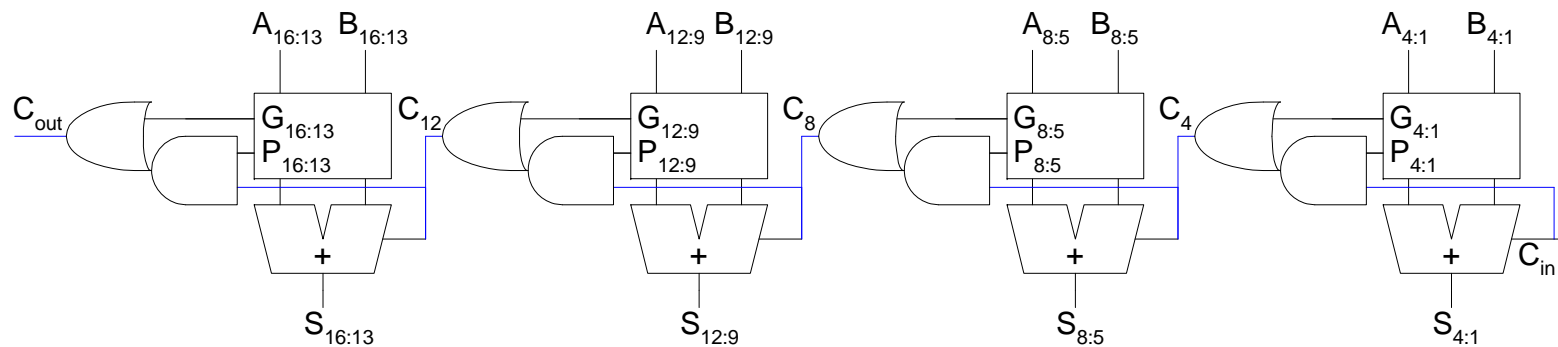

CLA PG Diagram

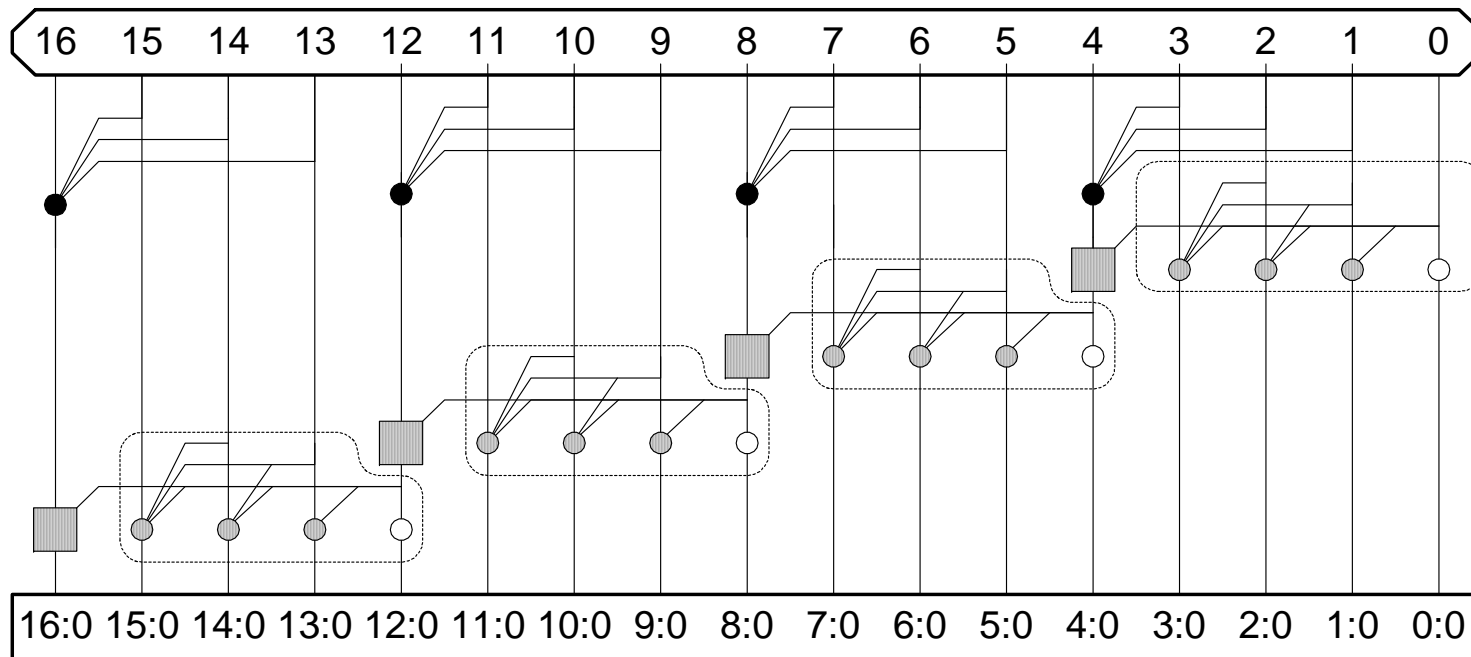

Higher-Valency Cells

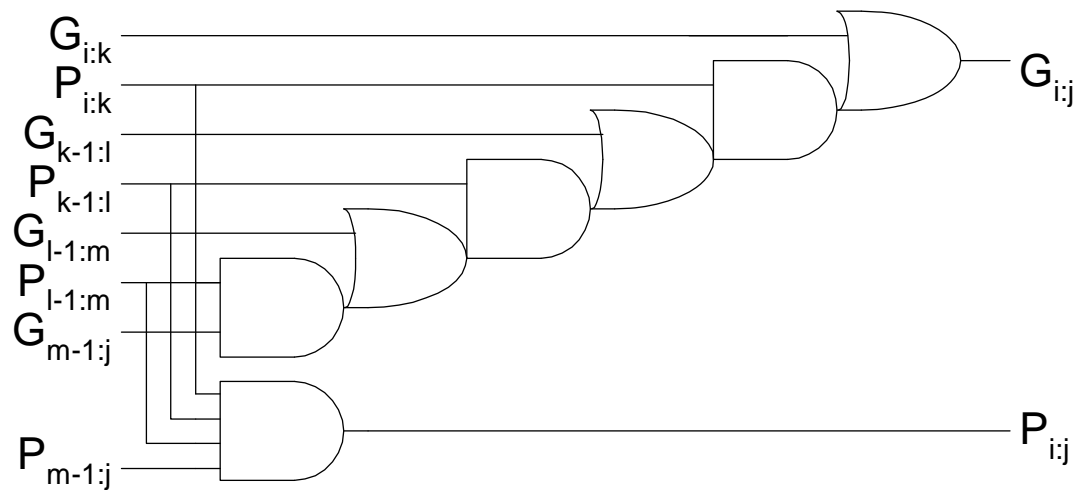
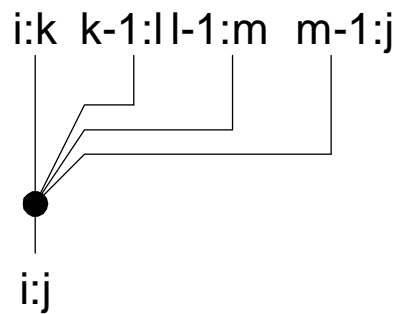

Carry-Select Adder

- ❑ Trick for critical paths dependent on late input X
 - Precompute two possible outputs for $X = 0, 1$
 - Select proper output when X arrives
- ❑ Carry-select adder precomputes n -bit sums
 - For both possible carries into n -bit group

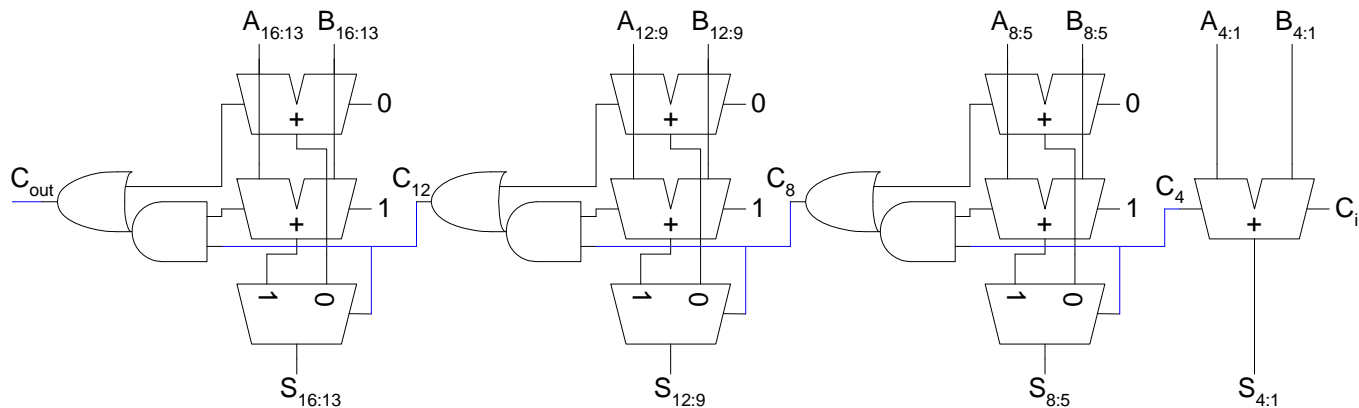

Carry-Increment Adder

- Factor initial PG and final XOR out of carry-select

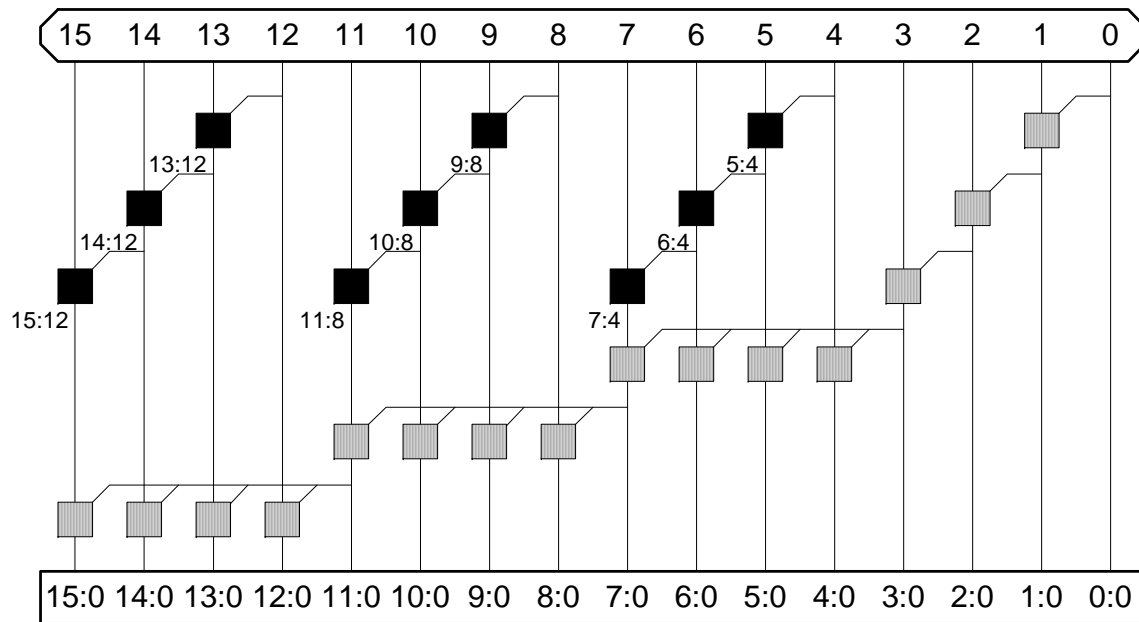

$$t_{\text{increment}} =$$

Carry-Increment Adder

- Factor initial PG and final XOR out of carry-select

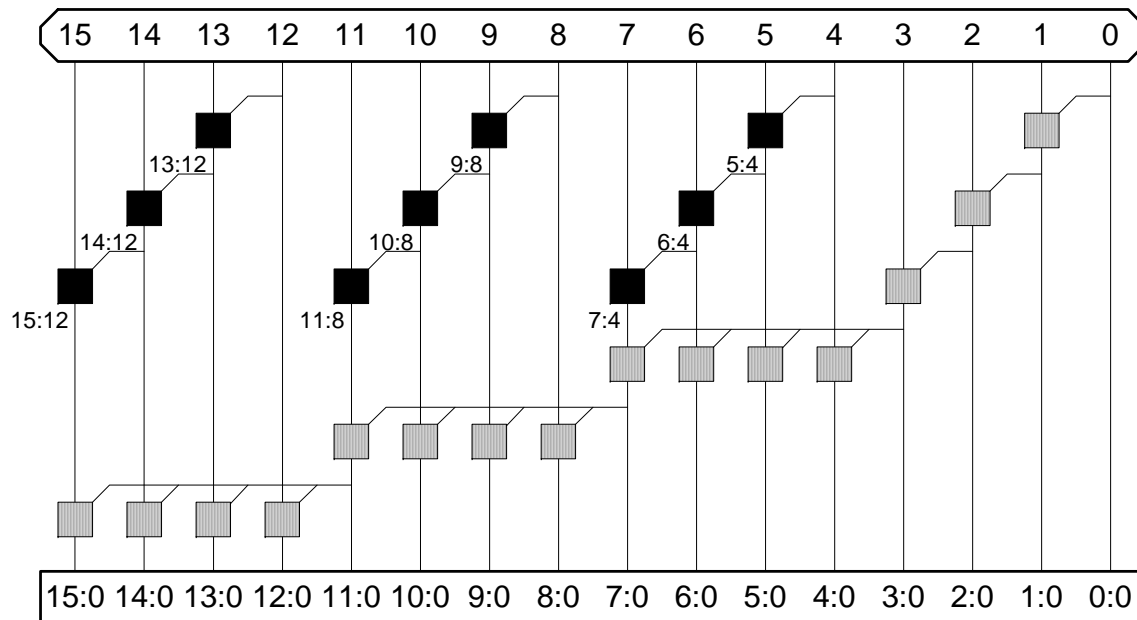

$$t_{\text{increment}} = t_{pg} + \left[(n-1) + (k-1) \right] t_{AO} + t_{\text{xor}}$$

Variable Group Size

- Also buffer noncritical signals

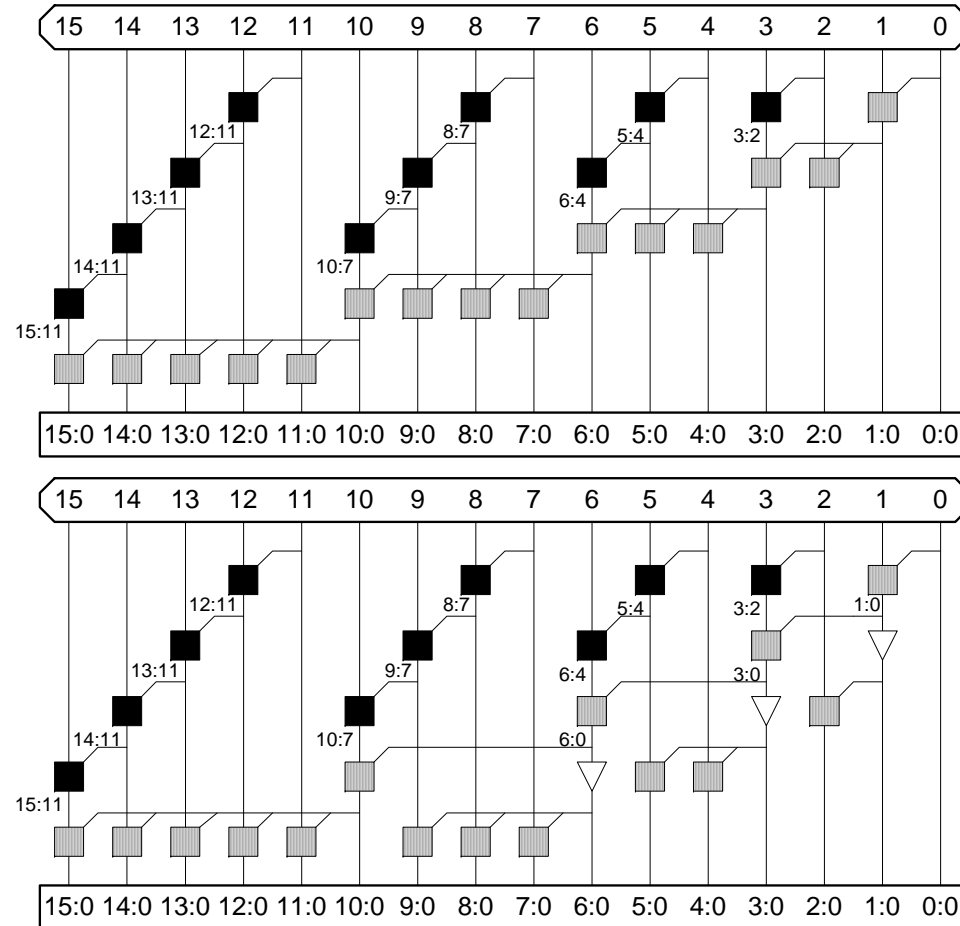

Tree Adder

- ❑ If lookahead is good, lookahead across lookahead!
 - Recursive lookahead gives $O(\log N)$ delay
- ❑ Many variations on tree adders

Brent-Kung

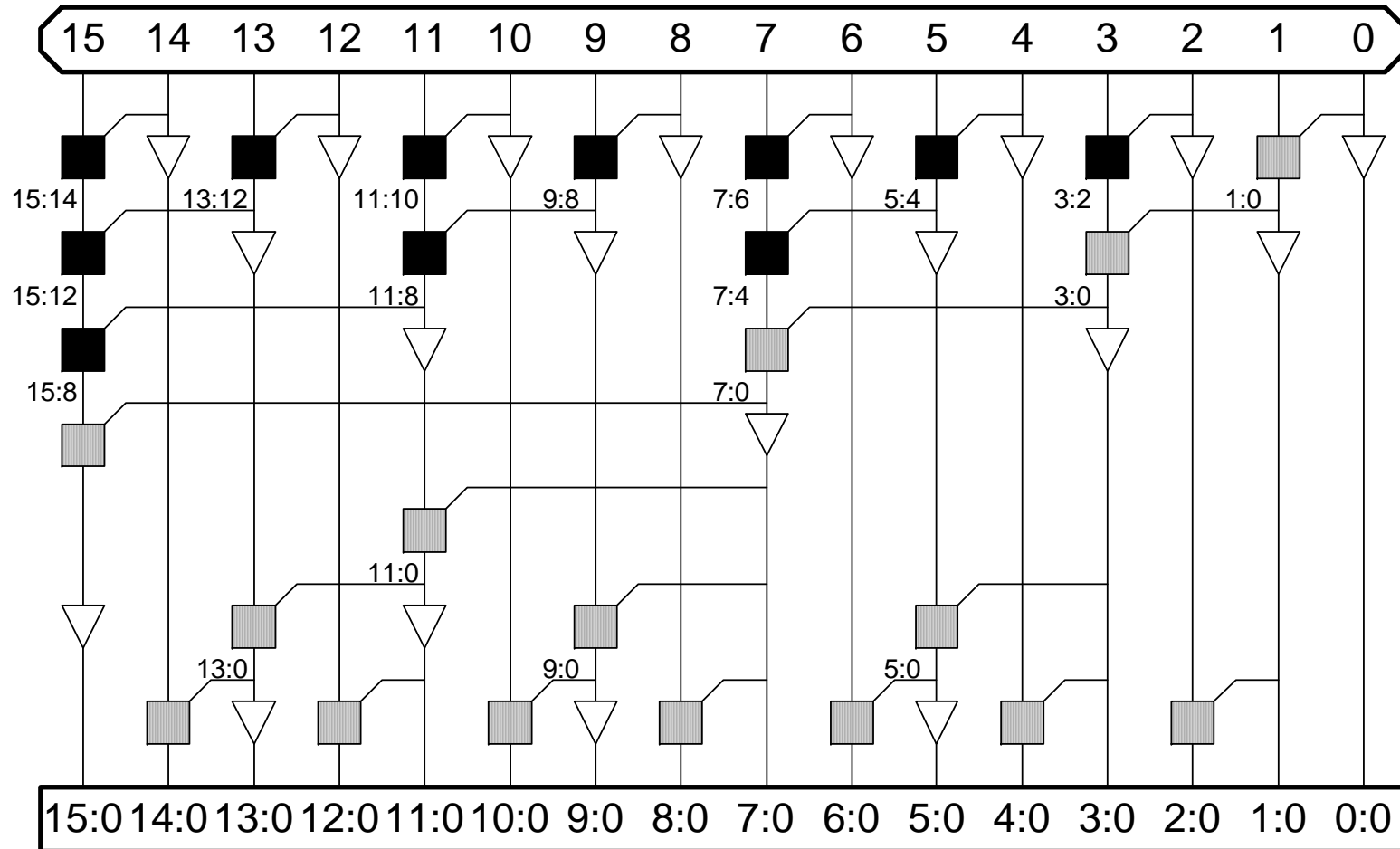

Sklansky

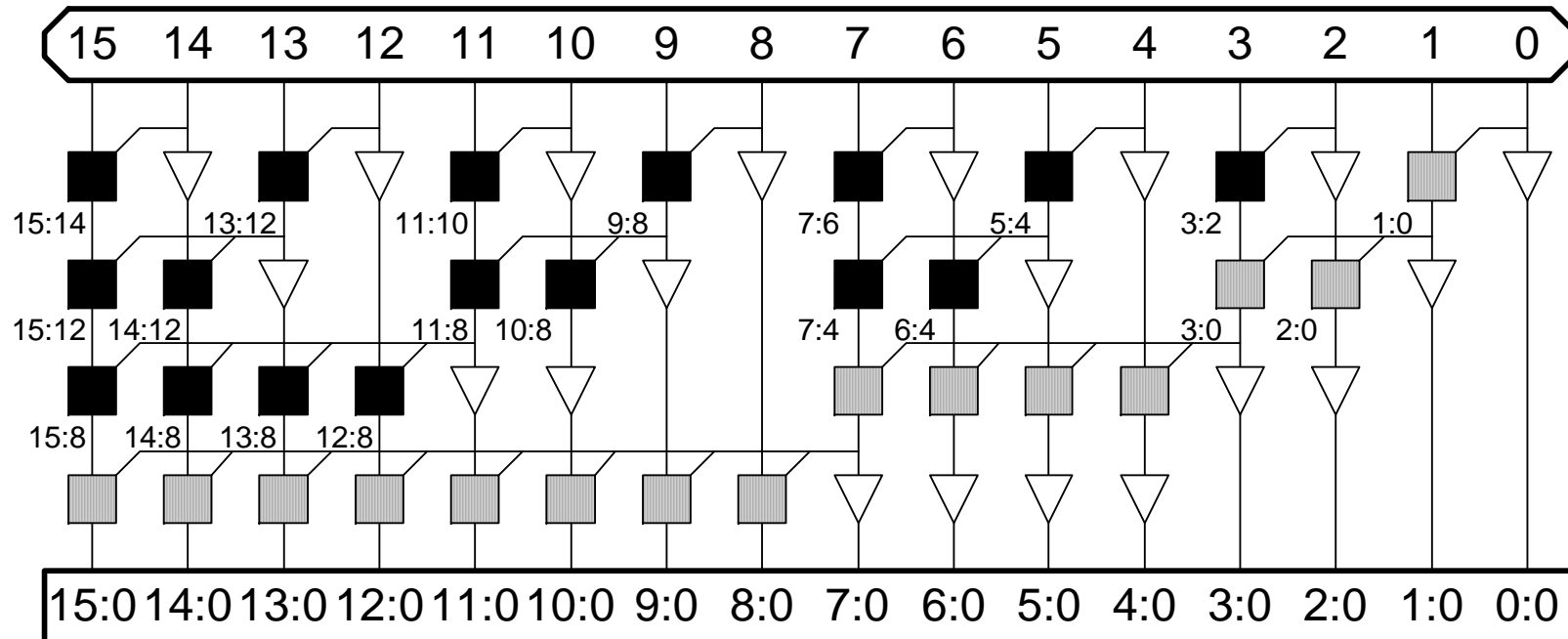

Kogge-Stone

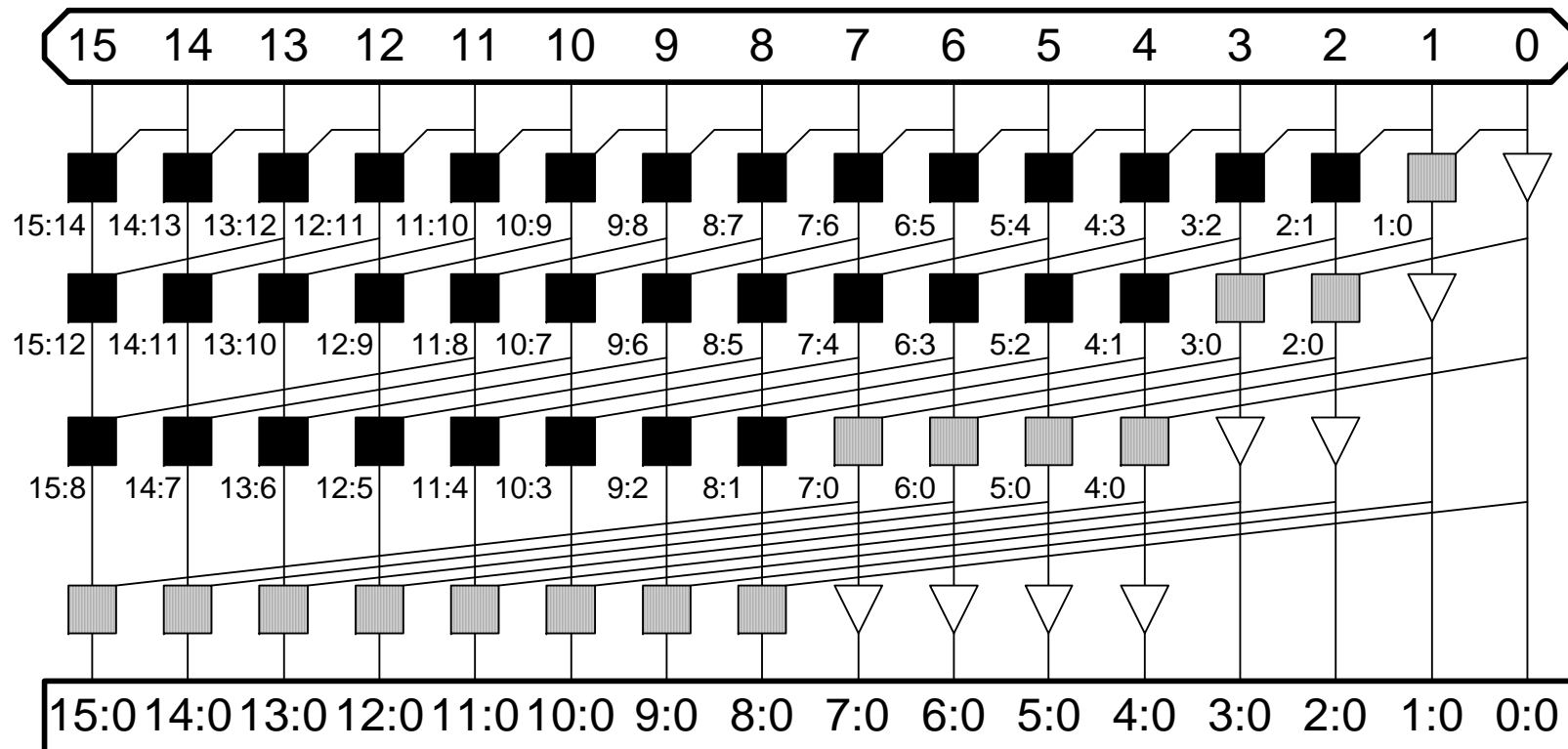

Tree Adder Taxonomy

- ❑ Ideal N-bit tree adder would have
 - $L = \log N$ logic levels
 - Fanout never exceeding 2
 - No more than one wiring track between levels
- ❑ Describe adder with 3-D taxonomy (l, f, t)
 - Logic levels: $L + l$
 - Fanout: $2^f + 1$
 - Wiring tracks: 2^t
- ❑ Known tree adders sit on plane defined by
$$l + f + t = L - 1$$

Tree Adder Taxonomy

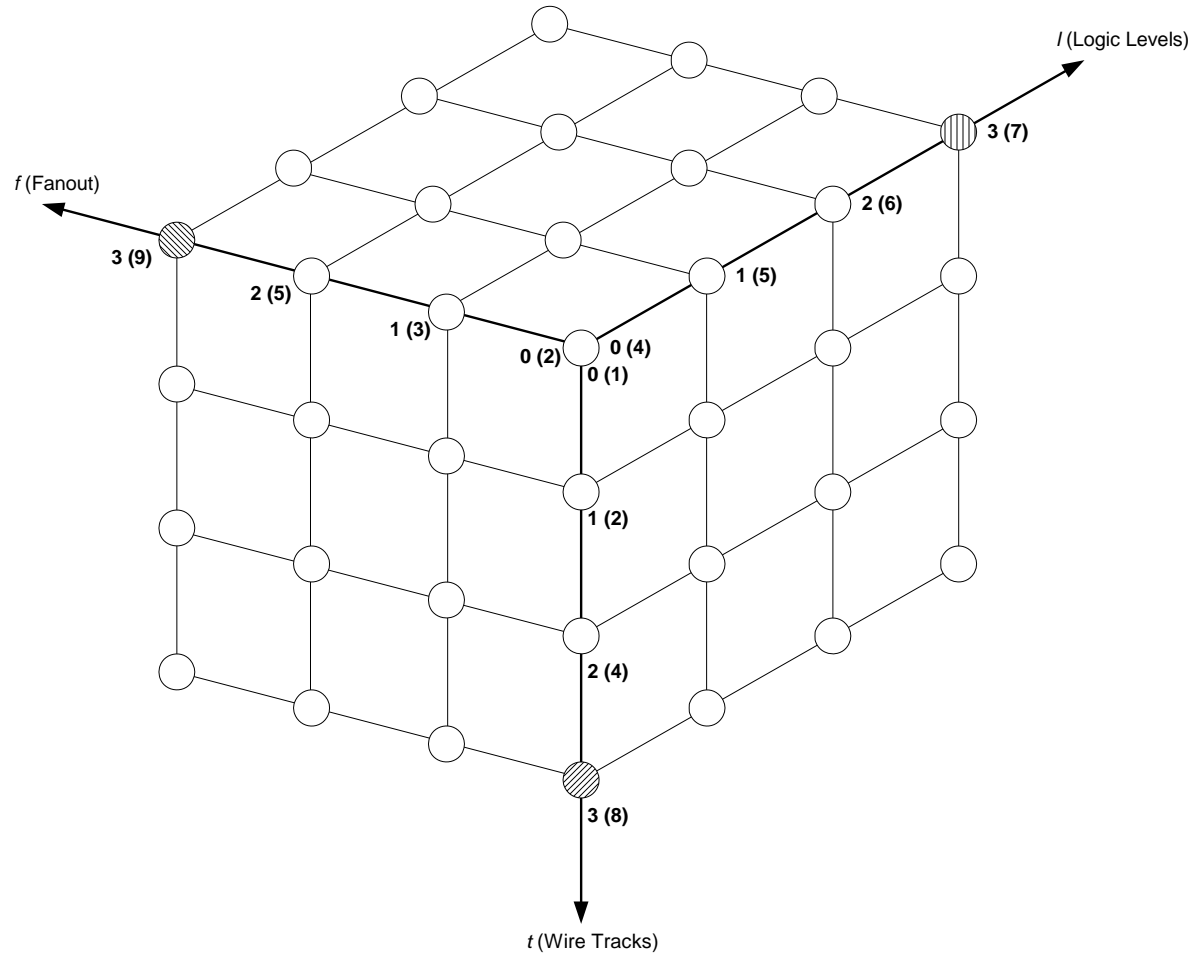

Tree Adder Taxonomy

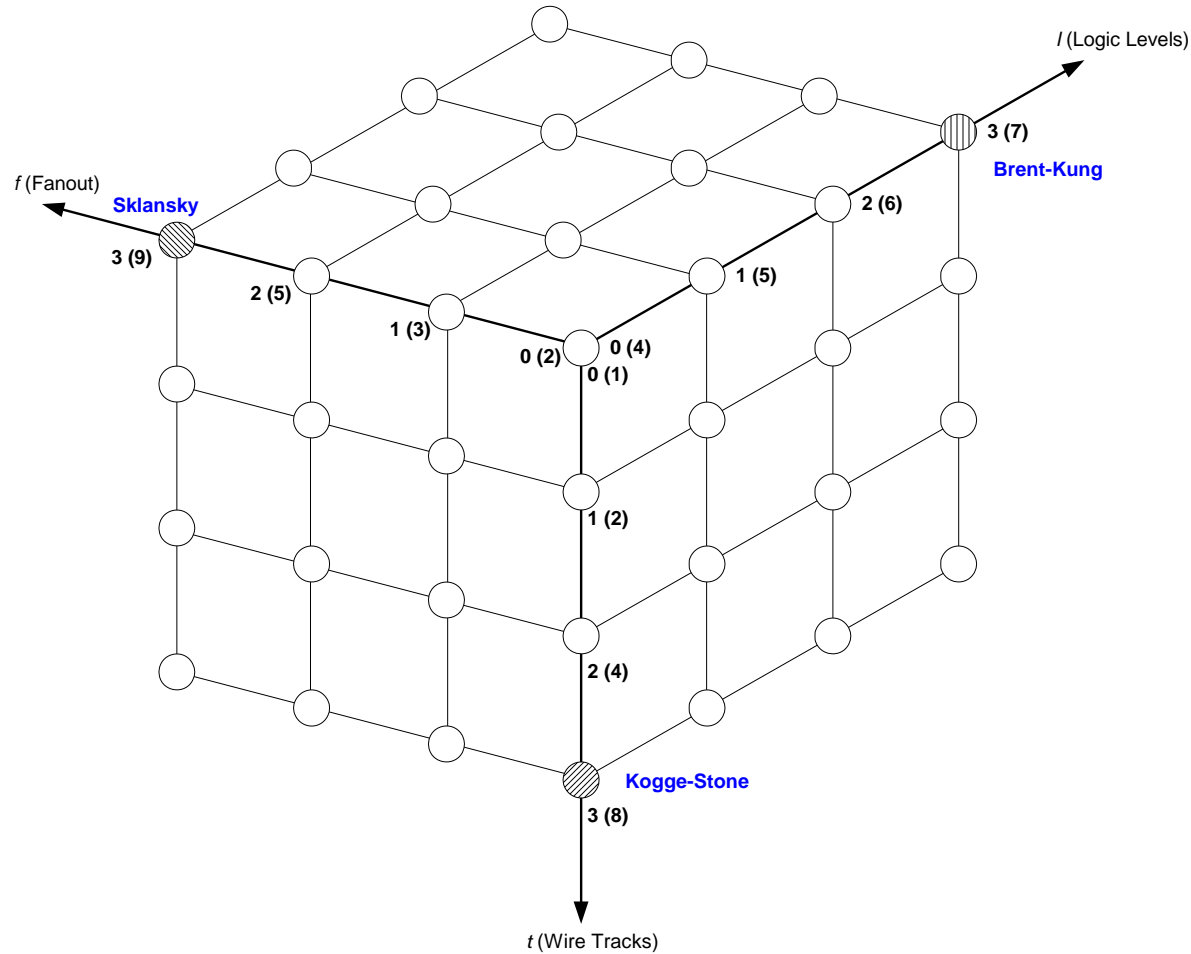

Han-Carlson

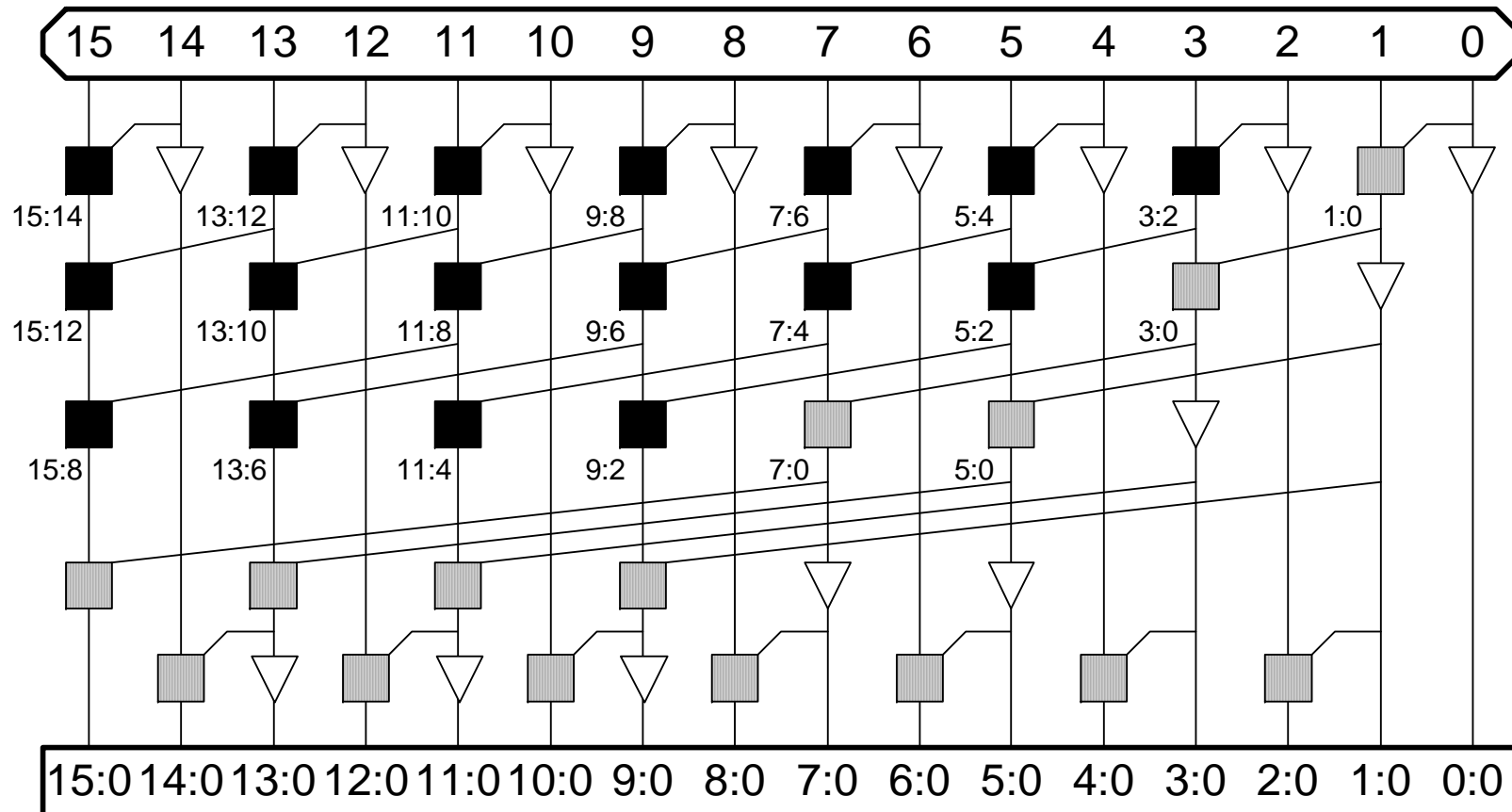

Knowles [2, 1, 1, 1]

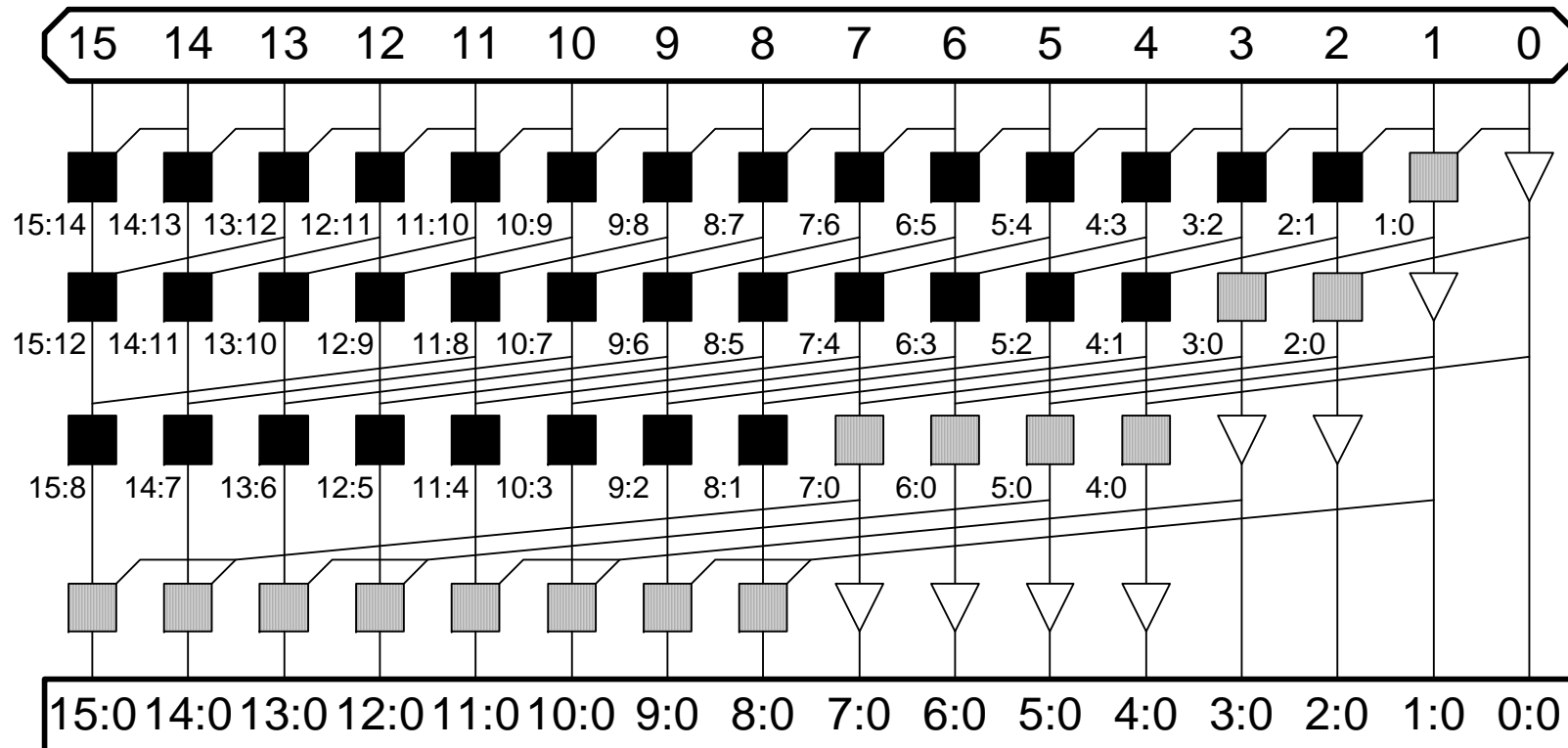

Ladner-Fischer

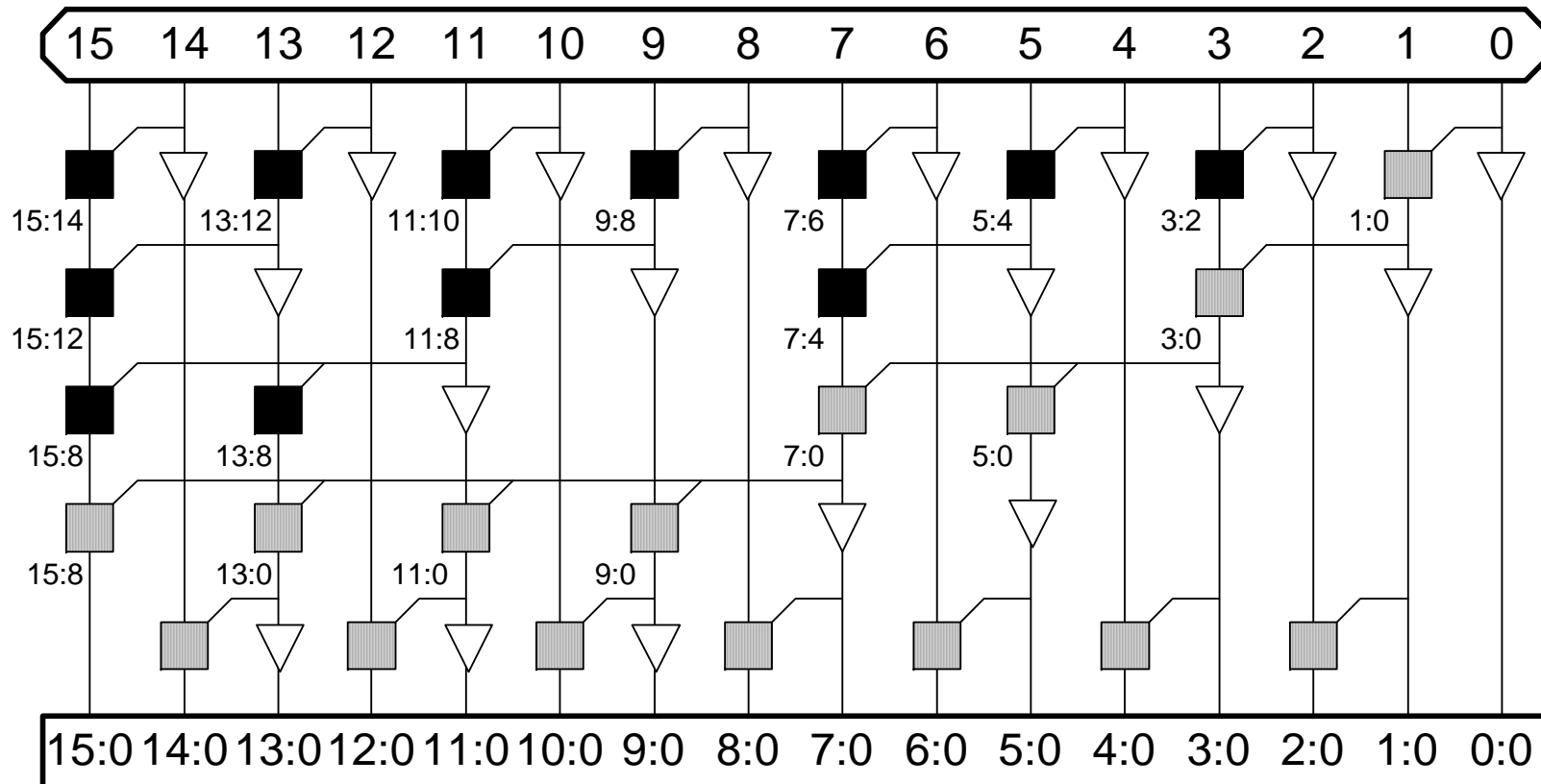

Taxonomy Revisited

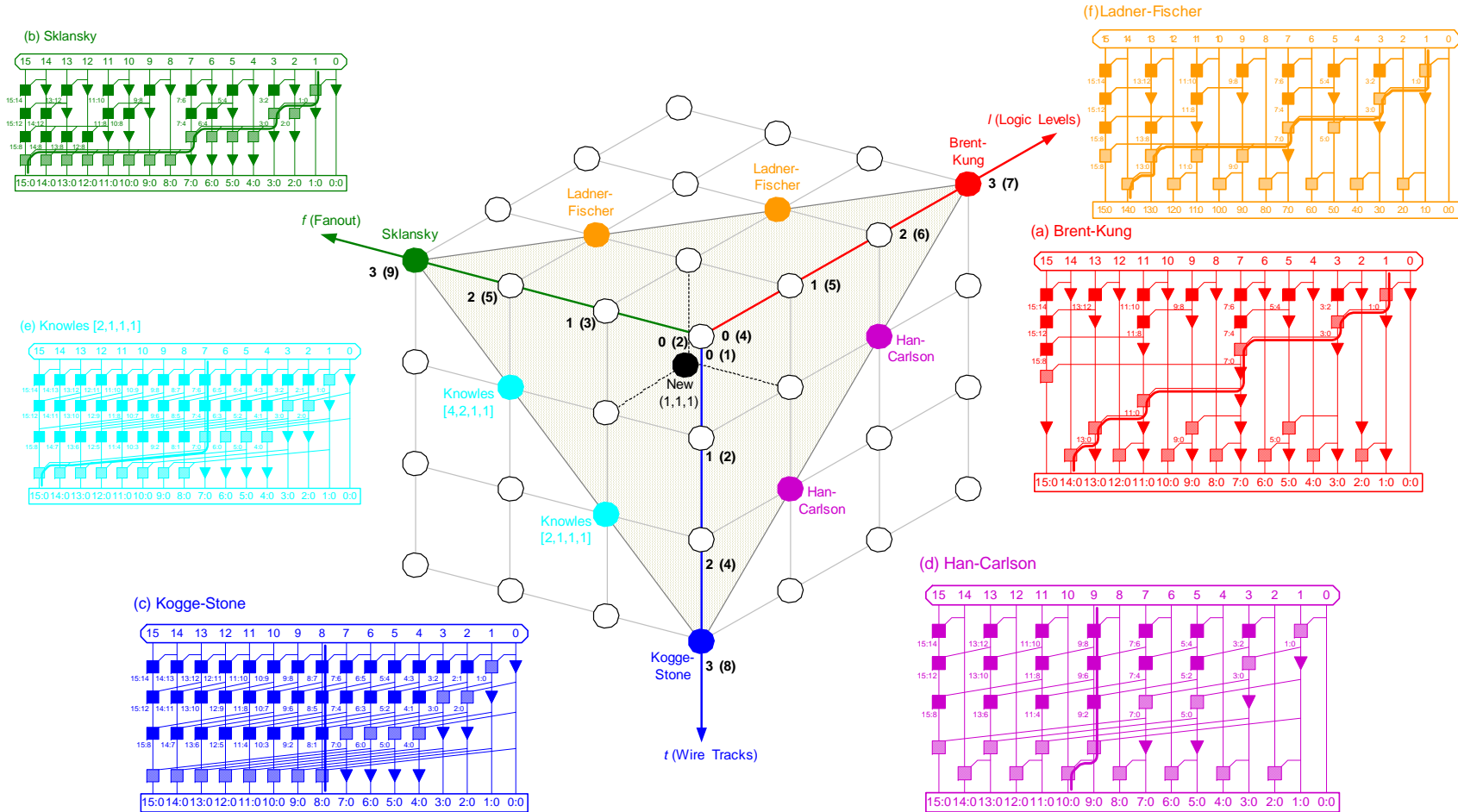

Summary

Adder architectures offer area / power / delay tradeoffs.
Choose the best one for your application.

Architecture	Classification	Logic Levels	Max Fanout	Tracks	Cells
Carry-Ripple		$N-1$	1	1	N
Carry-Skip $n=4$		$N/4 + 5$	2	1	$1.25N$
Carry-Inc. $n=4$		$N/4 + 2$	4	1	$2N$
Brent-Kung	$(L-1, 0, 0)$	$2\log_2 N - 1$	2	1	$2N$
Sklansky	$(0, L-1, 0)$	$\log_2 N$	$N/2 + 1$	1	$0.5 N \log_2 N$
Kogge-Stone	$(0, 0, L-1)$	$\log_2 N$	2	$N/2$	$N \log_2 N$